



24 hours
BUILT TO WORK
www.staxx-mhe.com



BUILT TO WORK
24
HOURS

HIGH RETURN OF INVESTMENT
PRODUCTIVE
1 MONTH COST RECOVERY
Safety

Pay A Little More Save Much More

SMART SIZE

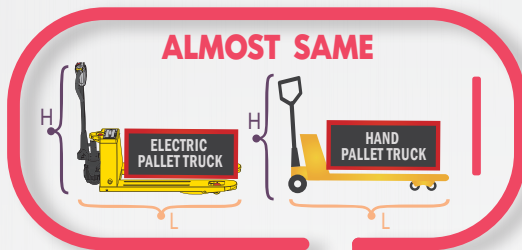

LIGHT WEIGHT

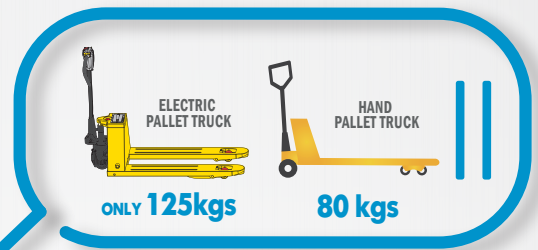

EFFICIENCY

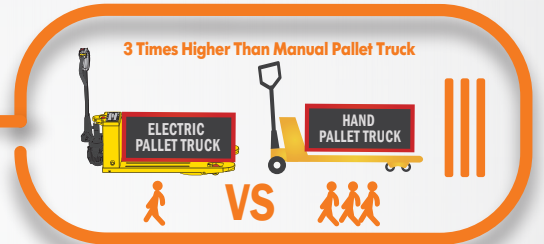

EASY MAINTENANCE

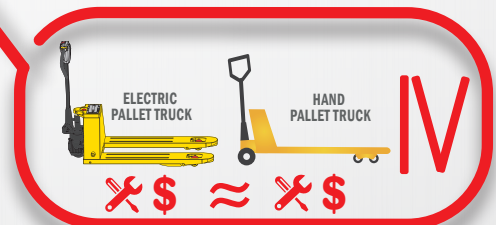

LIFETIME

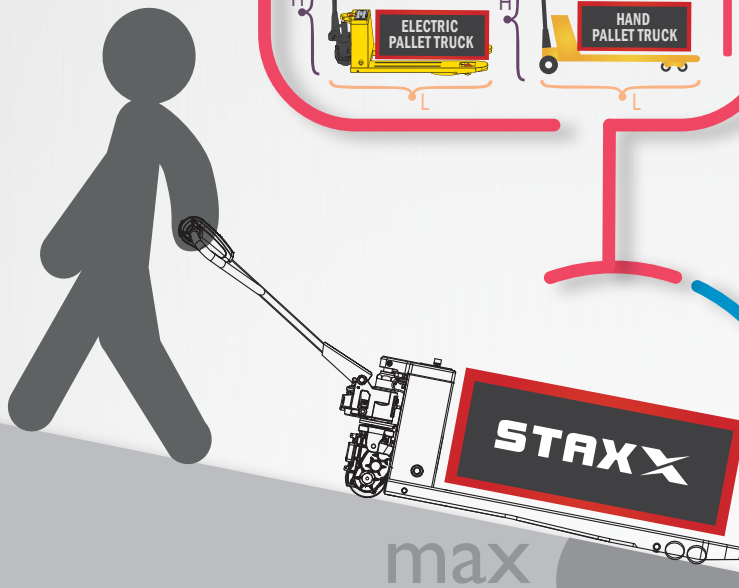
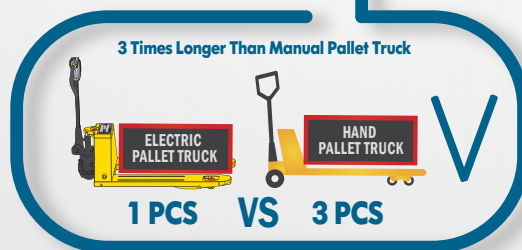

GO

Optimize your operations
Release manpower
SAVE LABOUR
Brake any time anywhere

● MAINTENANCE SO EASY !!

5 YEAR WARRANTY CHASSIS



Brushless drive motor, maintenance free



Lithium battery maintenance free

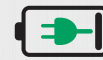

Recharge Alert



Error code display



6s Replace Battery



60s Replace Drive Wheel

● PERFORMANCE



Traveling speed

— **UNLADEN** 5Km/h

+ **LADEN** 4Km/h 3.5Km/h

Model: PPT18H

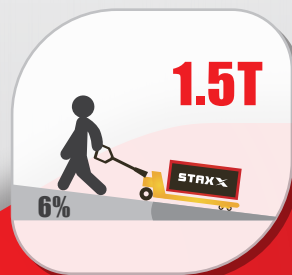

Model: PPT18H



Gradeability

● CHARACTERISTICS

Closer look into



Horn

Emergency reverse button

Forward/reverse butterfly switch

Lifting / Lowering

LCD Screen

- ◆ Battery indicator with hour meter
- ◆ Error code display
- ◆ Recharge Alert

EPT15H Multi-function Handle

PPT18H Multi-function Ergonomic Handle

Lithium battery pack



★ Tandem/Single PU wheel

Integral Forks

Ideal design for closed pallet(single load wheel)

★ Manual

★ Manual(Quick Lift)

★ Protection cover

Electric Lifting/Lowering

★ Fast Charger option(2hrs)

SMART FUNCTION



SMART FUNCTION

01

Turtle Speed

Horn Remains Pressed & Forward 2 times

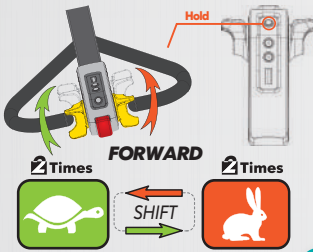

SMART FUNCTION

02

Up-Right Drive

Reverse Button & Forward Throttle Remain Pressed, Power On

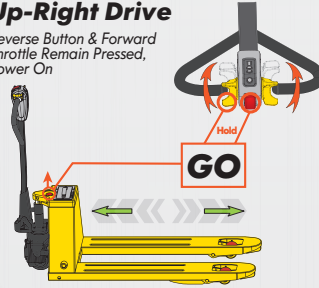

SMART FUNCTION

03

Engineering Mode (Brake Release)

Horn Remains Pressed, Power On

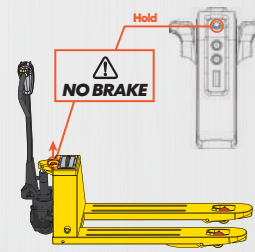

⚠ In up-right drive mode, vehicle will move when handle is operated at any position. Please avoid misoperation.

⚠ Brake release mode is only for emergencies, not allowed for vehicle with normal conditions.

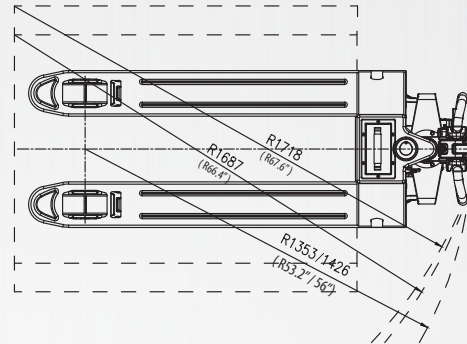
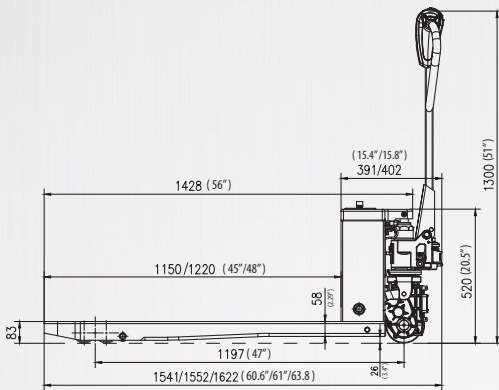

MODEL		PPT18H	PPT18HQ	EPT15H		PPT40H	PPT40HQ	EPT33H		
CHARACTERISTICS										
1.1	Capacity	kg	1800	1800	1500	lb	4000	4000	3300	
1.2	Load center	mm	600	600	600	in	23.6	23.6	23.6	
1.3	Standard overall fork width	mm	550/685	550/685	550/685	in	21.6/27	21.6/27	21.6/27	
1.4	Fork length	mm	1150/1220	1150/1220	1150/1220	in	45/48	45/48	45/48	
1.5	Overall length	mm	1552/1622	1552/1622	1552/1622	in	61/63.8	61/63.8	61/63.8	
1.6	Overall height (with tiller)	mm	1300	1300	1300	in	51	51	51	
1.7	Rear body width	mm	550/685	550/685	550/685	in	21.6/27	21.6/27	21.6/27	
1.8	Minimum turning radius	mm	1353/1426	1353/1426	1353/1426	in	53.2/56	53.2/56	53.2/56	
PERFORMANCE										
2.1	Max. Traveling speed	laden	km/h	3.5	3.5	4	mph	2.2	2.2	2.5
		unladen	km/h	5	5	5	mph	3.1	3.1	3.1
2.2	Gradeability	laden	%	5	5	6	%	5	5	6
		unladen	%	20	20	20	%	20	20	20
2.3	Traveling	kw	DC 0.75 Brushless	DC 0.75 Brushless	DC 0.75 Brushless	kw	DC 0.75 Brushless	DC 0.75 Brushless	DC 0.75 Brushless	
2.4	Lifting	kw	Hydraulic	QUICK LIFT	DC 0.5	kw	Hydraulic	QUICK LIFT	DC 0.5	
BATTERY										
4.1	Voltage	v	48	48	48	v	48	48	48	
4.2	Capacity/type	Ah	10 Ah Lithium	10 Ah Lithium	10 Ah Lithium	Ah	10 Ah Lithium	10 Ah Lithium	10 Ah Lithium	
BRAKE TYPE										
5.1	Travel brake		Regenerate	Regenerate	Regenerate		Regenerate	Regenerate	Regenerate	
5.2	Brake		Electromagnetic	Electromagnetic	Electromagnetic		Electromagnetic	Electromagnetic	Electromagnetic	
CONTROLLER										
6.1	Controller		STAXXB1501	STAXXB1501	STAXXB1501		STAXXB1501	STAXXB1501	STAXXB1501	

MAKE
YOUR JOB
EASIER!

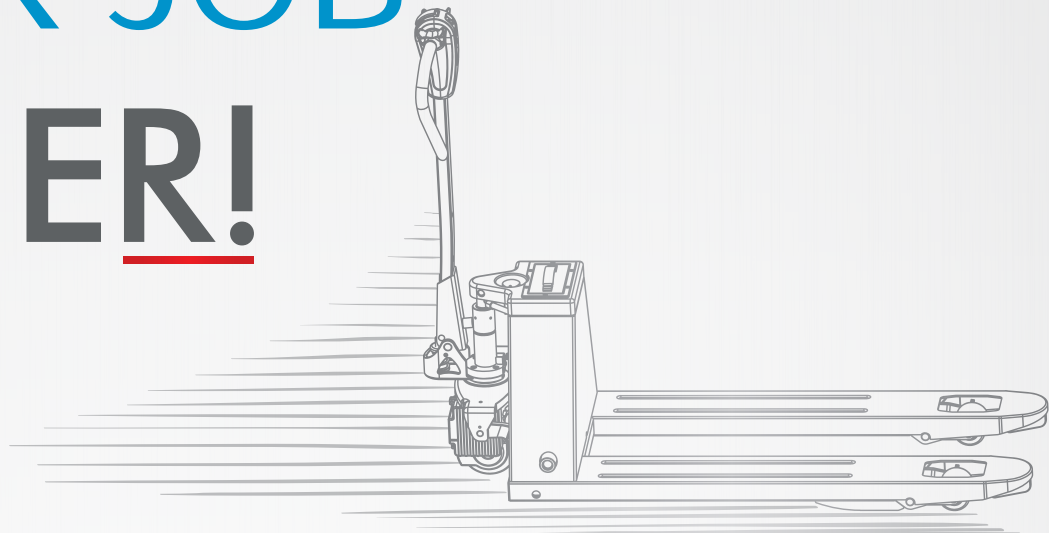

STAXX[®]
STAXX MATERIAL HANDLING EQUIPMENT CO., LTD

NINGBO STAXX MATERIAL HANDLING EQUIPMENT CO., LTD

Email: info@cnmhe.com **Tel :** **86-574-8921-7230**

Web: www.staxx-mhe.com **Fax:** **86-574-8921-7240**

Add: FIRST FLOOR, NO.10 BUILDING, NO.688 JINDA ROAD,
YINZHOU DISTRICT, NINGBO