

機台特色

- ※ 無害氣、噪音污染。
- ※ 車體輕巧、省作業空間。
- ※ 易操作、好保養、工作效益高。
- ※ 採用歐美進口高品質：驅動主機、液壓系統、微電腦無段式速度控制系統等原裝零組件，品質穩定。
- ※ 獨特的液壓式驅動主機懸吊設計，對地摩擦力穩定，能源效率更高。
- ※ 配備歐洲名牌原裝大型工業電瓶，可做長時間的連續作業。

Features

- ※ DC-24V power, no gas and noise pollution.
- ※ Compact, easy operate and maintenance.
- ※ Robust construction with high quality driving, lifting and speed controlling components, to provide the best performance.
- ※ Five points wheels touch to the ground, safety and stability in driving.
- ※ Equipped the deep cycle batteries and automatic power charger.
- ※ Low cost and high economic efficiency.

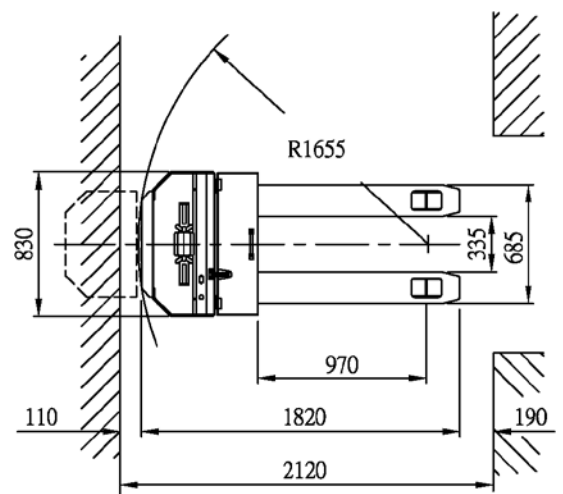
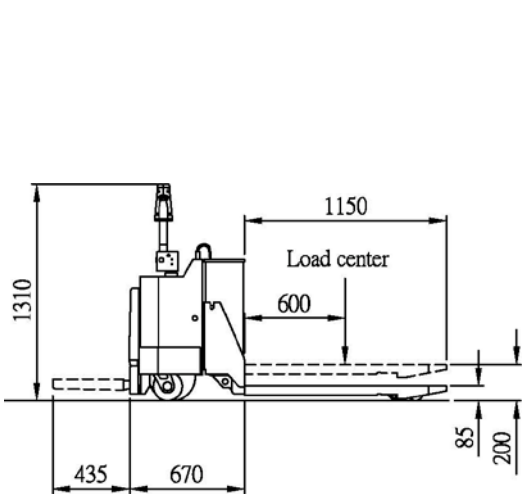

規格說明 Specifications

型式	Model		LPT-22S	LPT-30S
負載能力	Loading capacity	kg.	2200	3000
動力源	Power source		DC-24V	DC-24V
行走馬達	Driving motor	kw.	AC-1.2	AC-1.5
昇降馬達	Lifting motor	kw.	2.0	2.0
空載行走速度	Empty driving speed	km/h	6.0	6.0
負載行走速度	Loaded driving speed	km/h	5.5	5.5
空載爬坡能力	Empty gradient	%	16	16
負載爬坡能力	Loaded gradient	%	8	8
操作方式	Operating type		立乘式 Stand ride	
揚昇高度	Lifting height	mm.	200	200
迴轉半徑	Turning radius	mm.	1655	1655
直角通道寬	Angle stacking aisle	mm.	2120	2120
機台長度	Overall length	mm.	1820	1820
機台寬度	Overall width	mm.	830	830
煞車器	Brake		電磁式 Electric	
行走控制器	Driving controller		微電腦無段式 Transistor	
驅動輪	Driving wheel	mm.	230 / 70	230 / 70
負載輪	Loading wheels	mm.	80 / 70	80 / 70
輔助輪	Auxiliary wheels	mm.	150 / 50	150 / 50
電瓶	Battery	Ah/5hr.	180	180
電瓶重量	Battery weight	kg.	180	180
機台重量	Weight with battery	kg.	650	700
充電機	Power charger		DC-24V/30A	DC-24V/30A

本公司保留本產品的設計變更權力，變更時未能一一通知，敬請見諒。
本公司並接受客戶特殊指定規格或尺寸設計製造。

We reserve the data right to improve the products without prior notice and if you have any questions or special requirements please don't hesitate to contact us.